



**NIGHT VISION MONOCULAR**  
**STARGATE M**

---

In USA: 2331 Superior Ave. Cleveland, OH 44114  
In Canada: 105 Sparks Ave., Toronto, ON M2H 2S5

# IMPORTANT INFORMATION

## Read prior to activation

You have just purchased a complicated electronic device. To operate it properly, please read this manual carefully. Here are some common precautions that must be noted.

 **NEVER** expose the opened objective lens of an active unit in daylight. (Note: 1st generation units will still remain active for a few minutes after switching the unit off). At daytime objective lens must be covered by caps. There is a tiny hole in the cap to provide enough light for daytime operation. It is allowed to turn on the unit at daytime, but caps must cover the lenses.

 **NEVER** aim active unit at intense light sources (i.e. lights, headlamps, campfires, the moon, etc.)

 **NEVER** disassemble the unit

 Proper operation of the activation lever: Push it down and hold in this position. That should provide 30-60 seconds of operation (or more). Once the screen begins to get dimmer boost the image by releasing the handle and pushing it down again after a few seconds (not immediately!). Pumping the lever up and down rapidly is wrong! That will deactivate the power mechanism. You will need to wait 15-30 minutes before activating it again. Doing so repeatedly will cause irrecoverable damage to the activation mechanism.

 The unit is extremely sensitive to bright light. Never use in daytime with caps off. Even when using in daytime with caps on, the environment might be too bright. This will cause the unit to shut off automatically, and it may need up to 1 hour to recover. Doing so repeatedly will cause irreparable damage to the device.

# ATTENTION!

Image quality of the object, which is being observed when an image intensifier is functioning, depends mainly upon operating characters of this image intensifier. Due to this fact black spots, which are inherent in the image intensifier, may be seen in the field of view of a viewing device. Field of view is shown below.

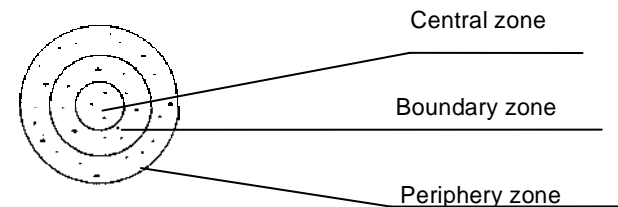

Permissible defects, which may be seen in the field of view, are provided in the following table

Type of black spots	Zone	Size of black spots, mm	Number of spots
Immovable	Central (circle of diameter 5.5 mm)	Up to 0.073 From 0.073 to 0.150 From 0.150 to 0.294	Not limited 5 1
	Boundary (circle of diameter 5.5-9.0 mm)	From 0.073 to 0.150 From 0.150 to 0.294 From 0.294 to 0.400	10 3 1
	Periphery (circle of diameter 9.0-11.0 mm)	Not limited	Not limited
Moving	Entire field (circle of diameter 11.0 mm)	From 0.150 to 0.294	1

## **10. ACCEPTANCE CERTIFICATE**

### **NIGHT VISION DEVICE STARGATE M**

Serial Number \_\_\_\_\_

Model Stargate M corresponds to technical conditions ADSH 3.807.020 TU and is admitted for use.

Date of production \_\_\_\_\_

Place for seal

Quality inspector \_\_\_\_\_

(Signature)



For best performance, keep the device in a dry place when not in use. Long-term exposure to high humidity environment will cause irrecoverable damage to the activation mechanism.

#### **Warning!**

After transportation or keeping the device at temperature lower than -25°C (-13°F), the device must be warmed up to an ambient temperature, from -20°C (-4°F) to +40°C (104°F) during 2-3 hours.

#### **Precaution**

Stargate M is a precision optical instrument equipped with electronics. Therefore, it should be handled with due care:

- Keep your device away from direct sunlight, impacts, dust, moisture, and sudden changes of temperatures.
- Do not touch the optical surfaces with fingers. Doing so may damage the anti-reflection coating.
- Cleaning of optical surfaces is possible only with professional camera lens cleaning supplies.
- To clean the exterior of the device, use only a soft clean cloth.
- Do not take the cover off the lens if not necessary.
- Keep away from heating appliances and central heating.
- Do not apply superfluous efforts at work with lens assembly, agile elements and thread connections.
- Due to considerable optical magnification of the eye-piece some small structures inside the tube coating in the form of dark and/or white points may be seen in the field of view which does not affect the serviceability of the device;
- The resolving power (resolution) may change in the direction from the center towards the perimeter of the field of view. This is an inherent feature of the image intensifier tube type utilized in the device. We would recommend placing the scene of observation in the center of the field of view.

## **CONTENTS**

- a. Warnings
- b. Precautions
- 1. Overview
  - i. Application and Advantages of STARGATE- M
  - ii. Features
- 1. Specifications
- 2. Construction
- 3. Operating Instructions
- 4. Care and Maintenance
- 5. Troubleshooting
- 6. Warranty
- 7. Customer support
- 8. Acceptance Certificate

**THANK YOU FOR PURCHASING STARGATE M NIGHT VISION DEVICE. PLEASE DEMAND TO CHECK THE DEVICE FOR PROPER OPERATION WHEN BUYING IT. PLEASE READ ALL THE INSTRUCTIONS CAREFULLY BEFORE USING.**

### **1. OVERVIEW**

Stargate M Night Vision scope is a sophisticated optical-electronic observation device designed to allow observations of personnel and orientation in nighttime conditions. The unit is utilizing an image intensifier tube, which amplifies available moonlight, starlight or man-made light. The viewer was designed to be easy to use, convenient to carry and provide many years of operation. The Stargate M utilizes piezocrystals as a source of high voltage power for the image intensifier tube. By means of a special lever mechanism piezocrystals are exposed to pressure and high voltage is produced on the piezocrystals, which is supplied to the image intensifier tube. This enables to conduct surveillance in the dark, by the actuating handle being kept pressed down continuously.

The above method of power supply to the image intensifier tube eliminates the use of batteries and high voltage converters. This development, besides making the product more affordable, enhances the reliability of night vision equipment and extends its service time.

NEWCON OPTIK may replace any product that has been discontinued or is out of stock, by another current product of comparable value and function.

**NEWCON OPTIK DISCLAIMS ANY WARRANTIES, EXPRESS OR IMPLIED, WHETHER OF MERCHANTABILITY OR FITNESS FOR A PARTICULAR USE, EXCEPT AS EXPRESSLY SET FORTH HEREIN.**

THE SOLE OBLIGATION OF NEWCON UNDER THIS LIMITED WARRANTY SHALL BE TO REPAIR OR REPLACE THE COVERED PRODUCT, IN ACCORDANCE WITH THE TERMS SET FORTH HEREIN. NEWCON EXPRESSLY DISCLAIMS ANY LOST PROFITS, GENERAL, AND SPECIAL, INDIRECT OR CONSEQUENTIAL DAMAGES WHICH MAY RESULT FROM BREACH OF ANY WARRANTY, OR ARISING OUT OF THE USE OR INABILITY TO USE ANY NEWCON PRODUCT.

### **9. CUSTOMER SUPPORT**

Should you experience any difficulties with your Newcon OPTIK product, consult the enclosed manual. If the problem remains unresolved, contact our customer support department at (416) 663-6963 or toll free 1-877-368-6666. Our operating hours are 9am-5pm Monday - Friday, standard East time. At no time should equipment be sent back to Newcon without following the instructions of our technical support department. Newcon accepts no responsibility for unauthorized returns.

To locate NEWCON Authorized Dealer call:

Tel: (416) 663-6963 Fax: (416) 663-9065

Email: [newconsales@newcon-optik.com](mailto:newconsales@newcon-optik.com)

Web: [www.newcon-optik.com](http://www.newcon-optik.com)

The defective products should be shipped to:

**From USA only:** 2331 Superior Ave. Cleveland, OH 44114

**From all other countries:** 105 Sparks Ave., Toronto, ON M2H 2S5, CANADA

*Condensation accumulates on the parts.*

It is O.K. to use the scope in cold. However, when the unit is brought from the cold into a warm environment, it has to warm up for up to 5 hours (not minutes!). Only then it is allowed to turn it ON again.

*Visibility decreases and / or disappears.*

Bright light sources (moon, projectors or headlights) may cause visibility to degrade or even completely disappear. Move the scope away from the light source immediately. The image should be restored in within 2 minutes. Poor atmospheric conditions such as fog, haze or extremely dark environments, will decrease the visibility distance of the unit

## **8. WARRANTY**

NEWCON OPTIK warrants this product against defects in material and workmanship for 3 months from the date of the original date of consumer's purchase, but no more than 12 months from the date of production being indicated and stamped on the acceptance certificate purchase. Should your NEWCON product prove defective during this period, please bring the product securely packaged in its original container or an equivalent, along with proof of the date of original purchase, to your NEWCON Dealer. NEWCON will repair (or at its option replace), the product or part thereof, which, on inspection by NEWCON, is found to be defective in materials or workmanship.

*What This Warranty Does Not Cover:*

NEWCON is not responsible for warranty service should the product fail to be properly maintained or fail to function properly as a result of misuse, abuse, improper installation, neglect, damage caused by disasters such as fire, flood, and lightning, improper electrical current, or service other than by a NEWCON Authorized Service. Postage, insurance, or shipping costs incurred in presenting your NEWCON product for warranty service is your responsibility. Please include a check or money order made out to NEWCON OPTIK for the amount of US\$10.00 to cover shipping and handling.

## **Features:**

- One stage image intensifier tube with Multi alkaline photocathode and image intensifier tube gain of no less than 500 times ensures observation at ¼ moon and better conditions;
- Optional AP 12 Infra Red illuminator allows observation in complete darkness
- Stargate M is intended for use within the range of illumination from 5/1000 lux to 1 lux at ambient temperature from -25°C to +40°C and relative humidity of no more than 80% at 20°C.
- High quality wide-angle lens.
- The internal lens with focusing mechanism ensures adjustment for sharpness for both near and remote objects
- The eye piece allows dioptric adjustment for the eyes
- Soft rubber eye-cap protects from the disturbing lateral light and occasional impacts, thus making surveillance more comfortable;
- Original compact design and ergonomic shape make the device handy and comfortable to hold with one hand

## **2. COMPONENTS**

Stargate M is supplied with the following components:

<b>NAME</b>	<b>QUANTITY</b>
Stargate M N.V, monocular	1
AP 12 I/R illuminator (optional)	1
Carrying strap	1
Case	1
Manual	1
Warranty Registration Card	1

## **3. SPECIFICATIONS of Stargate M**

Magnification, x	2
Field of View, degrees, not less	20°
Dioptric Compensation, Dptr., no less	±4
Focusing Range, m	3-∞
Lens focal length, mm	35
Eyepiece focal length, mm	9.5
Power Supply: The monocular	needs no batteries
AP 12 I/R illuminator	CR 123 Lithium Battery
Dimensions, mm	160X60X65
Weight, kg	0.450

NOTE: As the design is being continuously improved some descriptions may differ from those given above.

## 4.CONSTRUCTION

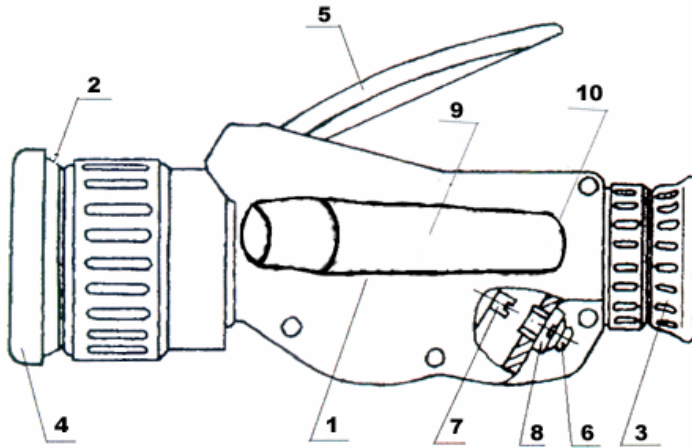

Picture 1

- |  |                    |               |
|--|--------------------|---------------|
| 1-Housing                              | 2-Lens             | 3-Eye-piece   |
| 4-Lens Cover                           | 5-Activation lever | 6-Screw Cover |
| 7-Pressure Adjustment Screw            | 8-Bushing          |               |
| 9- AP 12 Infra Red Illuminator         |                    |               |
| 10-I/R illuminator battery house cover |                    |               |

## 5. OPERATION INSTRUCTIONS

**WARNING! NEVER OPERATE YOUR NIGHT VISION DEVICE IN DAYLIGHT AREAS WITHOUT THE LENS COVER ON! NEVER DIRECT THE LENS IN THE DIRECTION OF BRIGHT LIGHT!**

Once in dark environment, take off the lens caps (4). Operation without the lens cover on is admissible only at the illumination level of no more than 1 lux (at this illumination one can read a newspaper text with difficulty after 5-10 minutes of eyes' adaptation = twilight and darker). Check the functioning of the device by switching it on: squeeze activation lever (5) and look through eyepiece (3). You should see a greenish-lit screen. Rotate eyepiece (3) to achieve sharpest image. In order to focus on a different distance, rotate the objective lens (2). If everything works, now is a great time to fill the warranty card.

Proper operation of the activation lever: Push it down and hold in this position. This should provide 30-60 seconds of operation (or more). Once the screen begins to get dimmer boost the image by releasing the handle and pushing it down again after a few seconds (not immediately!). Pumping the lever up and down rapidly is wrong! That will deactivate the power mechanism. You will need to wait 15-30 minutes before activating it again. Doing so repeatedly will cause irrecoverable damage to the activation mechanism.

When conditions are very dark, use the AP 12 Infa Red illuminator (9). Before usage, install a battery, observing the correct polarity.

## 6. CARE and MAINTENANCE

Maintenance includes only cleaning of parts if necessary.

6.1.Clean the lens and eyepiece optical surfaces with a soft cloth dampened with "lens cleaner" obtained from any camera store. Clean the lens surface carefully with circular movements starting from the center.

6.2.After a long period of use the brightness of the screen may decline when actuating lever is pressed. To regain normal brightness you should turn the pressure adjustment screw (7) a quarter ( $\frac{1}{4}$ ) of a turn clockwise. To reach the adjustment screw (7), first remove the screw cover (6) and the strap, than unscrew the bushing (8). This will expose an opening in the housing, so one can reach the adjustment screw.

## 7. TROUBLESHOOTING

*The scope does not work.*

Squeeze the lever all the way. Do not release it

*The image does not appear in focus.*

Bring the inspected object to the center of the image. Turning the eyepiece focusing (3) adjust to achieve the clearest image on the screen. Then obtain the most clear-cut image of the object by rotating the front lens (2). If the view still does not seem in focus, clean the lenses; they could be foggy or dusty.

*Unit flashes*

It is normal for the unit to flash within the first 2 minutes of activation. If the flashing continues afterwards the following is possible cause: bright environment (even with the cap closed!)